

Thank you for purchasing a FGWidget Converter!

Please take a moment to verify all of the parts of this kit you need are present:

- 1x FGWidget printed circuit board
- 1x 28 pin IC socket, probably clipped to the printed circuit board
- 1x 28 pin Atmel micro-controller
- 1x 10k ohm resistor (brown-black-orange) R1
- 2x 1.5k ohm resistors (brown-green-red) R2, R3
- 2x 0.1uF ceramic capacitors C1, C2

Overview:

The FGWidget converter is a small micro-controller based circuit board that reads the status of a connected PlayStation, Super Nintendo, or Sega Saturn board. Based on the buttons or directions pressed on the controller, matching pins on the converter will either drop to a low output voltage (if the matching button or direction is pressed on the controller), or to a high impedance with pull up resistor state (if the matching button or direction is not pressed on the controller). This output from the converter can be connected directly to a female Neo-Geo connector, or used in conjunction with any common ground controller board. As an example, this board can be used to make your own PSX->NeoGeo converter, or used with an MC Cthulhu board to make your own SNES->PS3 converter, or with a common ground Xbox360 controller board to make your own Saturn->Xbox360 converter.

Assembly: Assembly of the board is pretty straight forward. The IC socket needs to be soldered to the board over the 'FGWidget' label. There is a notch in one end of the silkscreen, and in one end of the IC socket; make certain they match. Once the socket is soldered in place, solder the 10k ohm R1 resistor to the spot marked 'R1 10k' on the board. Solder the remaining two 1.5k ohm resistors to the spots marked R2 and R3. Solder the two capacitors to the C1 and C2 points.

System Wiring: The next step is to decide whether the input controller will be a PlayStation controller, Super Nintendo controller, or Saturn controller.

If the PlayStation controller is to be used, wire up the female end of a sacrificed PlayStation extension cord directly to the matching pins shown on the bottom of the board. The unlabeled pin and the pin marked 'N/C' (for 'not connected') shouldn't be used and left alone.

If a Super Nintendo interface is to be used, locate the unlabeled solder jumper on the left of the board; they are two rectangular pads between the 'A' pin and the 'L2' pin. Use a dab of solder to connect those two pieces together. Doing this tells the board that the controller will be from a Super Nintendo. Wire up the female end of your Super Nintendo extension cord to the bottom pins according to the table on the other side.

If a Saturn interface is to be used, jumper the unlabeled solder jumper spot on the right of the board, just beside the C1 capacitor, then wire up the female end of your Saturn extension cord to the bottom pins according to the table on the other side.

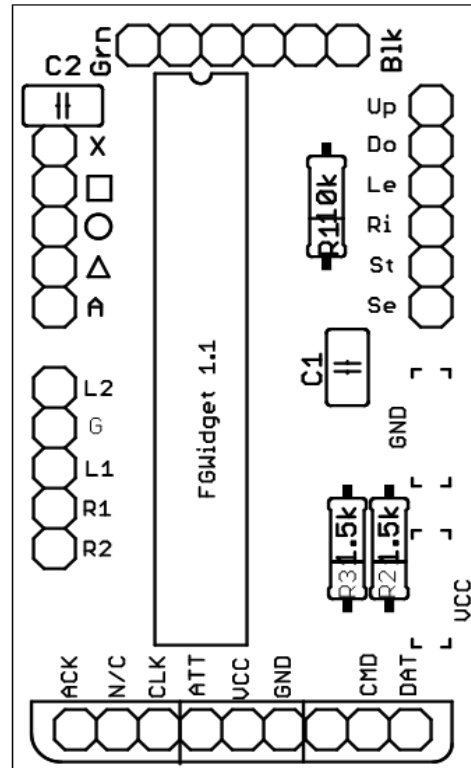

Cord Pin-out

Pin on board	PSX Pin	SNES Pin #	Saturn Pin #
ACK	9	-----	2
N/C	-----	-----	3
CLK	7	6	7
ATT	6	5	8
VCC	5	7	1
GND	4	1	9
CMD	2	-----	4
DAT	1	4	5



Source: <http://www.gamesx.com/controldata/snesdat.htm>

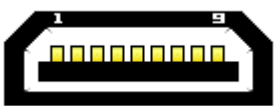

Source: <http://www.gamesx.com/controldata/saturn.htm>

Once the cord for your controller to plug into is complete, all that remains is to connect your converter to the PCB you want to control. Connect the power and ground to the VCC and GND points on the lower right side of the converter so the converter has power to run. Then connect the signal lines on the converter to the signal line on the controller you want to control. As an example, if you want to make your own Super Nintendo → Xbox360 adapter, find a common ground Xbox360 pad, connect the power and ground lines from the USB cable to the VCC and GND points. If you then connect the 'Up', 'Do', 'Le', and 'Ri' points to the four signal lines on the Xbox360's D-pad, any movement of the SNES controller's D-pad will act as the same movement on the Xbox360 pad.

Due to the very technical nature of this device, please understand that support of its use in your project will be either limited or nonexistent. While I've tried to make this as easy to use as possible, its use in any project will still require a fair deal of technical know-how. If it breaks, you keep both pieces. If this is not acceptable to you, please return the unused device in the condition it was received to where you purchased it.

Marcus “Toodles” Post, Sept. 2011

<p>Remapping: Hold Start+Select on your controller (just Start if a Saturn pad) for 20 seconds. When moving the Dpad no longer registers, you're in remapping mode. Press and release the buttons you to activate the Square line. Press and release the buttons you to activate the X line. Press and release the buttons you to activate the Tri line. Press and release the buttons you to activate the Circle line. Press and release the buttons you to activate the R1 line. Press and release the buttons you to activate the R2 line. Press and release the buttons you to activate the L1 line. Press and release the buttons you to activate the L2 line.</p> <p>That's it. Once you press and release the buttons that activate the eighth time, the settings are saved and the converter goes back to normal mode. If you dont want any button to activate the signal line, press either the Select button, or for Saturn, all eight play buttons at the same time.</p>	Pin on board	PlayStation	Super Nintendo	Saturn
	X	X	B	A
	Square	Square	Y	X
	Circle	Circle	A	B
	Triangle	Triangle	X	Y
	A	Start + Select	Start + Select	Start
	L2	L2	-----	R
	G	-----	-----	-----
	L1	L1	-----	L
	R1	R1	L	Z
	R2	R2	R	C
	Up	D-pad Up	D-pad Up	D-pad Up
	Do	D-pad Down	D-pad Down	D-pad Down
	Le	D-pad Left	D-pad Left	D-pad Left
	Ri	D-pad Right	D-pad Right	D-pad Right
St	Start	Start	Start	
Se	Select	Select	-----	